



# OMICRON WATER TECHNOLOGIES 2900UV series (STF 7000 series)



526 West 26 Street  
New York NY 10001  
212 366 6700

## INSTALLATION, OPERATION AND MAINTENANCE MANUAL

[www.omicronwater.com](http://www.omicronwater.com)

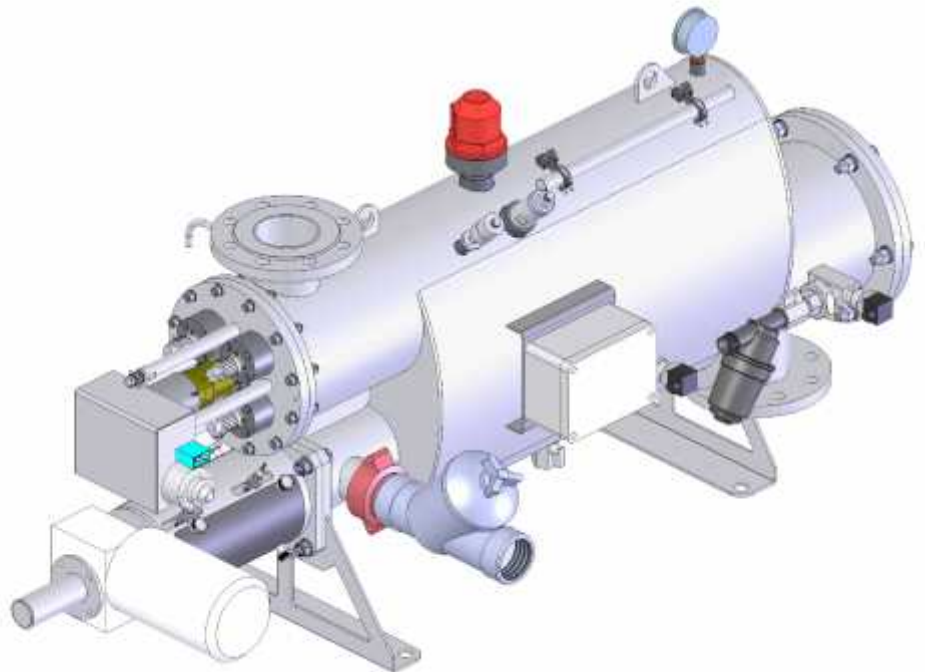

Ref: 7000

## CONTENTS

|  |    |
|--|----|
| 1. – INTRODUCTION.....                     | 6  |
| 2. – WARRANTY .....                        | 7  |
| 3. – SAFETY .....                          | 8  |
| 4. – 2900UV -- FILTER DESCRIPTION.....     | 10 |
| 5. – 2900UV -- OPERATION .....             | 13 |
| 6. – TECHNICAL FEATURES.....               | 16 |
| 7. – NAMEPLATE .....                       | 20 |
| 8. – INSTALLATION GUIDE .....              | 21 |
| 9. – START-UP INSTRUCTIONS.....            | 22 |
| 10. – MAINTENANCE GUIDE.....               | 24 |
| 11. – PREVENTIVE MAINTENANCE SCHEDULE..... | 25 |
| 12. – CONTROL PANEL .....                  | 27 |
| 12.1. – CONNECTION .....                   | 29 |
| 12.2. – OPERATION .....                    | 32 |
| 13. – WARNINGS AND ALARMS.....             | 38 |
| 14. – HYDRAULIC CIRCUIT .....              | 39 |

**IMPORTANT**

CAREFULLY READ AND FOLLOW THE INSTRUCTIONS IN THIS MANUAL BEFORE INSTALLING OR PERFORMING MAINTENANCE ON THIS DEVICE. THE MANUFACTURER IS NOT LIABLE FOR ANY DAMAGE CAUSED OR FOR ANY NEGLIGENCE RESULTING FROM NOT READING THE MANUAL.

This device has been manufactured in such a way that its performance does not bring about any risks for its designed usage, provided that:

Installation, management and maintenance must be carried out according to these manual instructions.

Facilities conditions and supply voltage must follow the specified instructions.

Any different usage from what is instructed will be incorrect. Unauthorized modifications are not permitted by the manufacturer. Damages resulting from incorrect usage will be the user's responsibility and will automatically void the warranty. Liability for injuries or damage caused by improper use of the device lies solely with the user.

Remember this device contains live electrical components; any servicing or maintenance work must be done by qualified experts abiding by necessary precautions. Disable the power supply before accessing internal parts.

**READ AND KEEP THESE INSTRUCTIONS**

We want to help you save time and money!  
We assure you that reading this manual completely will ensure  
the product is correctly installed and used safely.

**WARNING!**

RISK OF ELECTRIC SHOCK. OPERATIONS WITH THIS SYMBOL MUST ONLY BE PERFORMED BY QUALIFIED SPECIALIST TECHNICIANS.

**WARNING!**

HIGH INTENSITY ULTRAVIOLET RADIATION  
PROTECT YOUR EYES AND FACE  
DO NOT LOOK DIRECTLY INTO THE LIGHT.

**WARNING!**

0

ESSENTIAL INFORMATION AND FEATURES.  
THE DOCUMENTS ACCOMPANYING THE DEVICE ARE THE BASELINE  
REFERENCE.

**NOTE**

HIGHLY IMPORTANT INFORMATION AND FEATURES.

|  |  |
|--|--|
|  | <b>SISTEMAS DE FILTRADO Y TRATAMIENTO DE FLUIDOS, S.A.</b><br>Polígono La Armerura, parcela 87<br>22400 Monzón (Huesca)<br>ESPAÑA/Spain  |
|  | Tel: (+34) 974 40 19 33 / Fax: (+34) 974 41 78 09<br><a href="mailto:info@stf-filtros.com">info@stf-filtros.com</a> / <a href="http://www.stf-filtros.com">www.stf-filtros.com</a> |

**Declaración de Conformidad**   
 (Conforme a las Directivas Europeas 2006/42/CE sobre Máquinas-Anexo IIA,  
 Directiva 97/23/CE sobre Equipos a Presión y Directiva 2006/95/CE sobre Material Eléctrico)

**EC Declaration of Conformity**

(As defined by "Machinery Directive 2006/42/EC, Appendix IIA",  
 "Pressure Equipment Directive (PED) 97/23/EC" and "Electrical Equipment Directive 2006/95/EC")

Por el presente documento declaramos que los productos especificados a continuación cumplen los requisitos básicos de seguridad y salud conformes a las siguientes directivas que le son de aplicación:

*We hereby declare, that the products specified below meet the basic health and safety requirements of the above mentioned European Directives.*

DIRECTIVA SOBRE MÁQUINAS 2006/42/CE / (Machinery Directive 2006/42/EC, Appendix IIA)

|   |   |
|---|---|
| <b>DESCRIPCIÓN DE LA MÁQUINA:</b><br><i>Machinery description:</i>                            | <b>FILTRO DE MALLA AUTOLIMPIANTE ELÉCTRICO</b><br><i>ELECTRIC SELF-CLEANING SCREEN FILTER</i> |
| <b>FUNCIÓN:</b><br><i>Function:</i>   | <b>RETENCIÓN DE SÓLIDOS EN SUSPENSIÓN</b><br><i>SUSPENDED SOLID RETENTION</i>                 |
| <b>MODELO / TIPO:</b><br><i>Model / Type:</i>   |   |
| <b>NÚMERO DE SERIE:</b><br><i>Serial Number:</i>  |   |
| <b>LA MÁQUINA SE ENCUENTRA EN ANEXO IV?</b><br><i>Is the machine included in Appendix IV?</i> | <b>NO</b>   |

DIRECTIVA SOBRE EQUIPOS A PRESIÓN 97/23/CE / ("Pressure Equipment" Directive 97/23/CE)

Con arreglo al Apartado 3.9 del Artículo 1, de la Directiva 97/23/CE, los equipos que correspondan a lo sumo a la Categoría I, quedan excluidos de los requisitos de la presente Directiva.

*Based on Section 3.9 of Article 1, of this directive, the pressure equipment classified as no higher than category I, are excluded from the scope of this Directive.*

|   |  |
|---|--|
| <b>DESCRIPCIÓN DEL EQUIPO:</b><br><i>Equipment description:</i>                               | <b>FILTRO DE MALLA AUTOLIMPIANTE</b><br><i>SELF-CLEANING SCREEN FILTER</i>               |
| <b>PRESIÓN DE DISEÑO / TEMPERATURA DISEÑO</b><br><i>Design Pressure / Design Temperature</i>  | PN / °C  |
| <b>FLUIDO A CONTENER/ GRUPO S. D 67/548/CEE</b><br><i>Fluid / Fluid group S.D. 67/548/CEE</i> | AGUA / GRUPO 2<br><i>WATER / GROUP 2</i>   |
| <b>CATEGORÍA DEL EQUIPO / MÓDULO</b><br><i>S.D. 97/23/CE category / Module</i>                | <b>NO APLICA (APARTADO 3 ARTICULO 3)</b><br><i>NOT APPLICABLE (SECTION 3, ARTICLE 3)</i> |

DIRECTIVA SOBRE MATERIAL ELÉCTRICO DESTINADO A UTILIZARSE CON DETERMINADOS LÍMITES DE TENSIÓN 2006/95/CE / ("Directive 2006/95/EC to electrical equipment designed for use within certain voltage limits")

El Dossier Técnico de Fabricación de estos equipos se encuentran en nuestro domicilio social arriba indicado.

*The Technical construction file is maintained at the corporate address mentioned above.*

La maquinaria, equipo, montaje o su-montaje al que se refiere esta Declaración de conformidad no debe ponerse en funcionamiento hasta que la unidad a la que se incorpore haya sido declarada de conformidad con las disposiciones de la(s) Directiva(s) que le resulte(n) aplicable(s).

*The machinery, product, assembly or sub-assembly covered by this Declaration of Conformity must not be put into service until the machinery into which it is to be incorporated has been declared in conformity with the provisions of the applicable Directive(s).*

Monzón, \_\_\_\_\_ 201 \_\_\_\_\_

**D. Victor Clarimón Rami**  
 Dirección Industrial / General Manager

## 1. – INTRODUCTION

OMICRON WATER TECHNOLOGIES / STF FILTROS thank you for purchasing this Omicron 2900UV series (FMA-7000) self-cleaning mesh filter. All OMICRON / STF products are easy to install, use and maintain.

Should you have any queries about how the device works after reading the manual, please contact the technical department at STF-Filtros or technical support at Omicron in the US.

### CONTACT US



SISTEMA DE FILTRADO Y TRATAMIENTO DE FLUIDOS S.A

 +34 974 401 933

 +34 974 417 809

 [info@stf.filtros.com](mailto:info@stf.filtros.com)

[www.stf-filtros.com](http://www.stf-filtros.com)

## 2. – TWO YEAR WARRANTY

**SISTEMAS DE FILTRADO Y TRATAMIENTO DE FLUIDOS S.A.U.**  
 Pg. Armentera, 87 • 22400 MONZÓN (Huesca) SPAIN  
 Tel No.: (+34) 974 401 533 • Fax: (+34) 974 417 809  
[info@stf-filtros.com](mailto:info@stf-filtros.com) • <http://www.stf-filtros.com/>



### WARRANTY CERTIFICATE

#### TWO YEAR WARRANTY

As the manufacturers and responsible for the product you have purchased, at STF-Filtros we are convinced of the high quality of the product and warranty the equipment has no material or manufacturing defects and that if used correctly and maintained as specified in the manual, the product will fulfil the function for which it has been designed for a period of two years following the delivery date.

Subject to the limitations given below, STF-Filtros will repair or replace your product and/or reimburse the cost price of the product.

The two-year warranty is limited to covering the repair, replacement or return of the product and lasts for the twenty-fours (24) months established in this document.

#### Limitations and exclusions from the warranty

1. This warranty will be null and void under the following circumstances:

- a. Incorrect use, negligence or accident.
- b. Unauthorised modifications or incorrect installation of the product.
- c. Failure to observe the instructions for product installation and maintenance.
- d. Product repair or modifications by unqualified personnel.
- e. Power failures, flooding, fire, accidental breakage or any other events outside the control of STF-FILTROS.

2. The two-year warranty does not cover any transportation, customs clearance or any other costs arising from the return of the product, returning repaired products or replacing products, or any expenses associated with installing, removing or reinstalling the same.

3. The warranty does not cover any complaints in which the series type or number of the STF-Filtros product has been altered, removed or is illegible.

4. Due to the high degree of loyalty on the part of our clients, the warranty is only available to our direct clients.

|            |          |
|------------|----------|
| Model      |          |
| Series No. | ---/---- |

-----  
Issue Date

-----  
Delivery Note No.

-----  
Authorised Signature

## 3. – SAFETY

**INSTRUCTIONS ON HOW TO USE THE FILTER SAFELY**

INAPPROPRIATE USE OR INCORRECT MAINTENANCE OF THIS DEVICE  
MAY CAUSE THE USER PHYSICAL INJURY.

TO AVOID THESE RISKS, YOU ARE STRONGLY ADVISED TO ABIDE BY  
THE FOLLOWING INSTRUCTIONS:

ADOPT APPLICABLE ACCIDENT PREVENTION MEASURES TO  
GUARANTEE YOUR SAFETY AND THAT OF THE DEVICE.

- Do not touch moving parts.  
Never place your hands, fingers or any other body parts near the moving parts of the filter.
- **Do not touch the filter without protection.**  
Never use the filter without protections if they are not perfectly settled in place (e.g. Protection cover). If the maintenance operations require their removal make sure that before using the new filter the protections are well fixed in their respective places.
- Protection against electric shocks.  
Prevent accidental contact between the electrical and metallic parts of the device.
- Protection against ultraviolet radiation.  
While in operation, the device generates intense ultraviolet radiation.

**WARNING!**

HIGH INTENSITY ULTRAVIOLET RADIATION MAY CAUSE BLINDNESS.

SHIELD YOUR EYES AND FACE

- Disconnect the filter.  
Disconnect the device from the power source before performing any assistance, inspection, maintenance, cleaning, changing or part verification operations.
- Release filter pressure.  
Release pressure in the device before performing any assistance, inspection, maintenance, cleaning, changing or part verification operations.
- Working area.  
Maintain the working area clean and free of unnecessary tools. Sparks may be produced while the device is in operation; do not use the device in the presence of varnish, petrol or other flammable or explosive substances.



- Filter maintenance.

Follow the instructions in this manual: check the lubrication; regularly inspect the power cable and if it is damaged have it repaired by qualified personnel. Check the exterior has no visible anomalies.

- Ensure the screws, pins and cover are securely fastened.

Regularly check they are securely fastened.

- **Ensure the device operates at correct voltage.**

Pay attention to the voltage specified in this manual and on the filter information label.

- Never use **the filter if it is faulty**.

Should the filter make strange noises, excessive vibrations or seem faulty in any way, stop using it immediately and check its functionality.

- Only use genuine replacement parts.

The warranty is null and void if genuine replacement parts are not used.

- Do not modify the filter.

Unauthorized modification may lessen device performance and cause serious accidents to personnel who are not sufficiently technically aware.

- Disconnect and drain the device.

When the filter is not in use, disconnect the power source and drain the filter to extend its life.

#### 4. – 2900UV SERIES FILTER DESCRIPTION

The **2900UV** automatic mesh filter combines filtering with disinfection in a single unit, reducing the installation area and increasing system simplicity. The unit backwashes automatically without the need to interrupt the ongoing liquid filtration; additionally, it disinfects the liquid without the need for any chemical product to be added to the water - thus minimizing environmental impact.

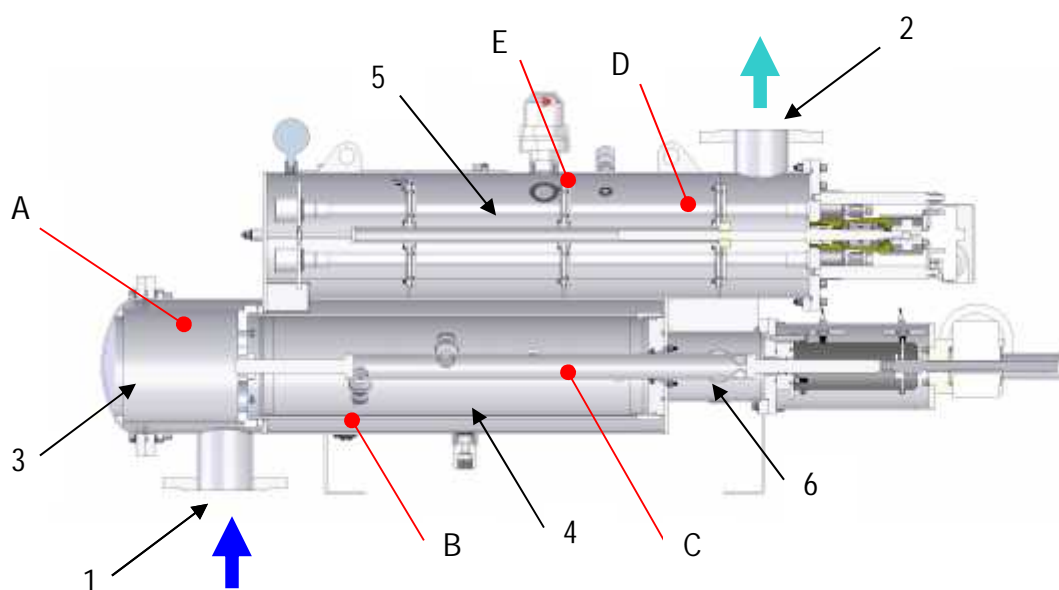

- 1 – Raw water inlet.
- 2 – Treated water outlet.
- 3 – Roughing chamber.
- 4 – Filtration chamber.
- 5 – Disinfection chamber.
- 6 – Backwashing chamber.

- A – Roughing cartridge
- B – Filtering cartridge.
- C – Cleaning scanner.
- D – UV lamps.
- E – Lamp cleaning sleeve.

The flow running through the unit is subject to two distinct processes. First there is filtration through a mesh filter, second there is disinfection by ultraviolet radiation. The roughing, filtration and cleaning chambers are for the first process, and the disinfection chamber for the second.

When water enters the filtration chamber, it slows down and the particles are retained in the form of a filter cake on the mesh (filtration size as chosen).

Once the liquid has gone through this first stage, it moves into the upper section of the filter via a duct inside the cartridge. At the end of the duct, the liquid meets a series of interwoven ultraviolet lamps that can destroy the DNA of bacteria and viruses by emitting C-type ultraviolet light at 254 nm.

The germ killing starts when the liquid begins heading towards the unit outlet; the liquid moves fast enough to receive the recommended dose for each application.

The lights may be switched on manually or automatically. Manually: There are two buttons to press, one to switch on and the other to switch off. Automatically: The lights come on when pressure is detected in the unit (i.e. there is water in it) and the temperature is below the switch-off threshold (settable parameter).

The 2900UV device is fully automatic, with two backwashing systems, one for the filtration mesh and one for the ultraviolet lamps.

Backwashing in the filtration stage can be started manually, by a timer (so the retained elements can be incrustated into the mesh) or as pressure differential is created by the build-up of dirt on the filtration mesh. When the set pressure differential is achieved (detected by analog pressure transducers), the unit begins a washing cycle that consists of opening the drainage valve and the rotation of a series of nozzles with nylon bristles that suck in the dirt retained by the filtration mesh. The backwashing cycles for the filtration mesh can be started manually or by using a timer.

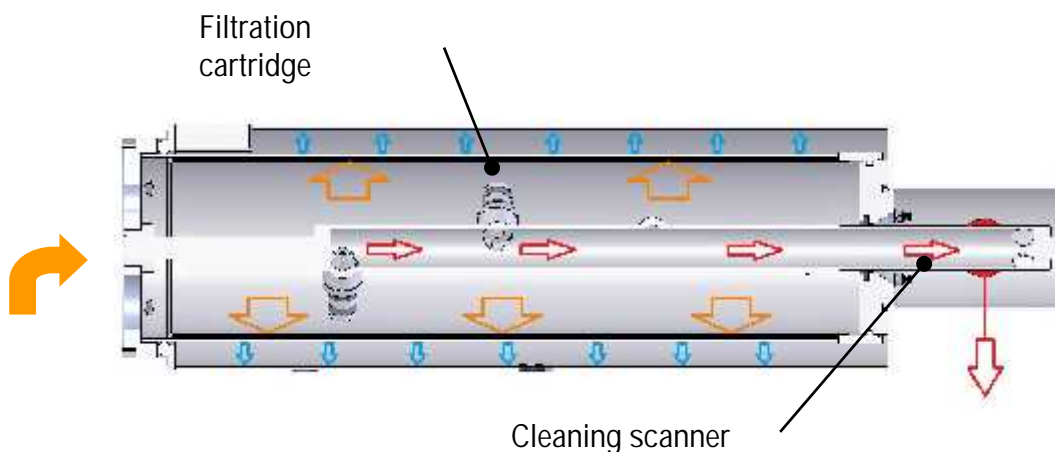

The ultraviolet lamps have an automatic system to clean the quartz protecting the lamp, so as to maintain the effectiveness of the system during the life of the lamps. The in-reactor backwashing can be started manually, by a timer (so as to avoid fouling by the particles in suspension) or upon a decrease in radiation emitted to below the minimum threshold (settable parameter).

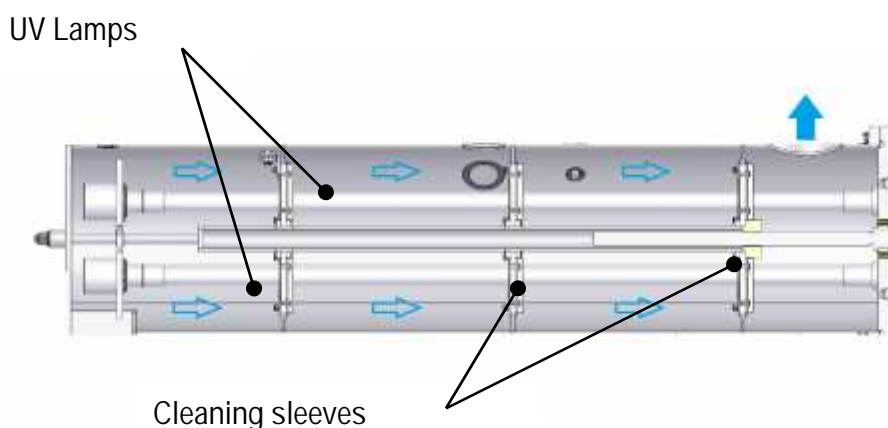

In recent years, ultraviolet light disinfection technology has been implemented as an alternative to chemical disinfection as it is more respectful towards the environment and has less environmental impact on water channels. However, this system has not always been implemented correctly: For the system to work correctly, it is necessary to filter the water so that it reaches the disinfection system in ideal conditions.

One of the problems that diminishes UV disinfection performance is the so-called "shadow effect", which occurs when the water enters the ultraviolet disinfection system with a high concentration of solids in suspension, of such volume that these solids prevent the radiation from reaching the organic substances that it is meant to degrade.

In order to avoid this, it is necessary to filter as a complement to the disinfection system.

The treatment unit from STF combines the two treatments in a single device, thus ensuring the disinfection system works correctly and, additionally, reducing the concentration of solids in suspension in water re-use systems.

As a result of its configuration, the 2900UV series is ideal for installation in wastewater treatment plants, refrigeration systems and industrial systems, as it assures water quality parameters, reducing financial costs both in implementation and in maintenance as well as considerably reducing the space required for assembly.

## 5. – 2900UV OPERATION

### FILTRATION STAGE

- The water reaches the filter via the roughing chamber; here any heavy particles are retained, just like with strainers.
- The water passes on through the FINE MESH, producing the SURFACE MECHANICAL FILTRATION phenomenon. High quality water is then obtained, ideal to avoid the "shadow effect" during disinfection.
- The dirt stays behind and accumulates on the inner surface of the fine mesh, causing a progressive loss of pressure between the filter inlet and outlet. Two analog transducers set in motion the washing sequence when the DP is equal to 0.3 bar (3 m.c.a.). There are two other ways to set the filter wash: timed washing (combination of time and pressure) and continuous washing.
- When the differential pressure shows 0.3 bar, the drainage valve is instructed to open. This generates a pressure differential between outside (atmospheric pressure) and inside the filter (working pressure) which induces a current of fast flowing water, which rushes through the mesh and out through the inner hole of the nozzles. In addition, at this point, the order is sent to the motor to start operating.
- The result of this collection of actions is a suction effect from the nozzles on the dirt on the mesh, and a spiral movement of the suction scanner inside the filter.
- During the self-cleaning process, the water continues to be filtered and flow towards the system or application. This is due to filter design and means that water consumption for washing is MINIMAL and the work flow is CONTINUOUS.

## DISINFECTION STAGE

- Once filtered, the water goes into the disinfection chamber, which contains 4 lamps which generate ultraviolet radiation.
- Ultraviolet radiation is characterized by wavelengths very similar to those of sunlight. The most important parameters of UV radiation for water disinfection are:

- Wavelength:

The germ killing range falls between 240 and 280 nm (nanometers) and maximum disinfection efficiency lies near 260 nm. These limits are within the range known as ultraviolet - C (100-280 nm), as compared to ultraviolet - A (315-400 nm) and ultraviolet - B (280-315 nm).

- Water quality:

Water temperature has little or no effect on the efficiency of ultraviolet light disinfection, though it does affect the operating performance of the ultraviolet lamp when this is immersed in the water. Ultraviolet energy is absorbed by water, but it is absorbed much more by solids that are in suspension or dissolved, turbid and colored.

- Intensity of the radiation:

The closer to water the rays are emitted, the greater their intensity and therefore the more efficient the disinfection. Therefore the general rule is that the water in the chamber must be no deeper than 75 mm to ensure that all of it is properly hit by the rays.

- Micro-organism type:

Ultraviolet radiation is measured in microwatts per square centimetre ( $\mu\text{W}/\text{cm}^2$ ) and the dose in microwatt seconds per square centimetre ( $\mu\text{Ws}/\text{cm}^2$ ) (radiation x time). Resistance to the radiation depends on the type of micro-organism. However, the dose of ultraviolet light required to destroy the most common micro-organisms (coliforms, pseudomonas, etc.) lies between 6,000 and 10,000  $\mu\text{Ws}/\text{cm}^2$ . The standards for ultraviolet light doses in different countries vary between 16,000 and 38,000  $\mu\text{Ws}/\text{cm}^2$ .

- Exposure time:

As with any disinfectant, the exposure time is critical to ensure good performance. There is no simple formula to specifically determine contact time, as this depends on flow type and equipment characteristics. But the period should be related to the necessary dose (per the above explanations and the concept of C x T). For a specific level of micro-organism inactivation, the exposure time for water to ultraviolet light is inversely proportionate to the intensity of light penetrating the water, taking into account water absorption capacity and light dispersion due to distance.

The disinfection method is simple: It consists of having the water flow in contact with an ultraviolet lamp such that the UV radiation acts on the micro-organisms under the aforementioned conditions producing the consequent disinfection effect.

- Water does not circulate freely through the chamber; the scraper support discs have two functions as they have openings designed to increase the transit time and to generate turbulence in the water.
- Lamp cleaning takes place automatically when reduction in the radiation emitted is detected.

6. – TECHNICAL FEATURES

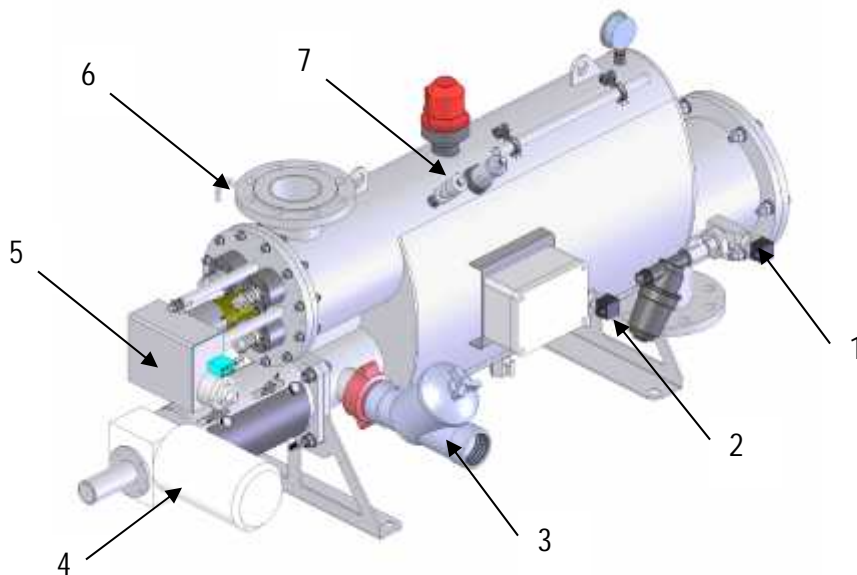

- 1 – Inlet pressure transducer
- 2 – Outlet pressure transducer
- 3 – Backwashing valve.
- 4 – Filter drive unit set.
- 5 – Backwashing drive unit set.
- 6 – Temperature sensor.
- 7 – UV radiation intensity sensor.

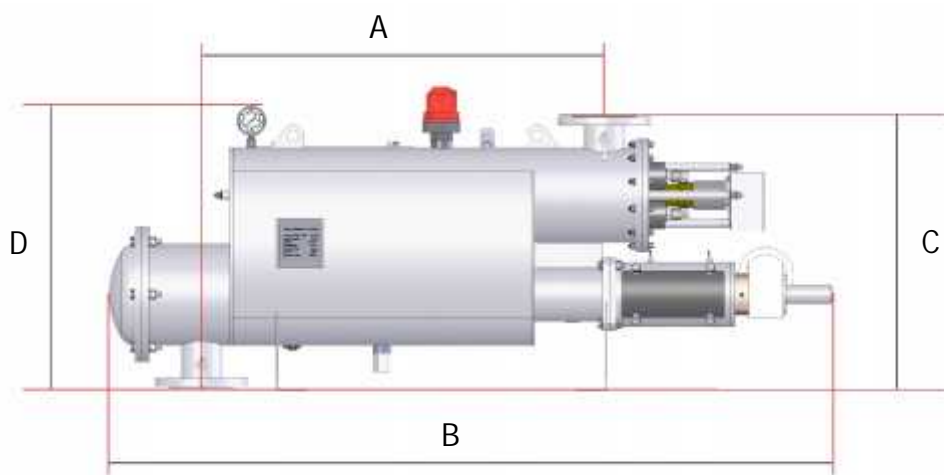

| MODEL         | DIMENSIONS (mm) |      |     |     |         | Net Filtering area (cm <sup>2</sup> ) |
|---------------|-----------------|------|-----|-----|---------|---------------------------------------|
|               | A               | B    | C   | D   | DN      |                                       |
| <b>2900UV</b> | 865             | 1555 | 580 | 675 | 80 (3") | 2.900                                 |



| MODEL                                    | 2900UV                      |            |
|--|-----------------------------|------------|
| <b>GENERAL CHARACTERISTICS</b>           |                             |            |
| Inlet/Outlet Diameter (1)                | DN-80 (3")                  |            |
| Max/Min working pressure                 | 2 bar / 10 bar              |            |
| Max. fluid temperature                   | 40 °C                       |            |
| STAINLESS STEEL MESH SUPPORT             | 25 microns                  | 50 microns |
| Max. Flow (gpm)                          | 65                          | 110        |
| Net filtering surface (cm <sup>2</sup> ) | 2.900                       |            |
| Unladen weight (kg)                      | 135                         |            |
| Laden weight (kg)                        | 200                         |            |
| Filtration sizes available               | 50, 25, 20 and 10 microns   |            |
| <b>BACKWASHING</b>                       |                             |            |
| Backwashing valve                        | G-2" thread                 |            |
| Backwashing min. pressure                | 2.5 bar / 36 psi            |            |
| Backwash cycle length                    | 26 seconds                  |            |
| Backwash flow (gpm)                      | 40                          |            |
| Backwash water consumption (litres)      | 17.2                        |            |
| <b>ELECTRICAL DATA</b>                   |                             |            |
| Supply voltage                           | 220 V AC 50 Hz Single-phase |            |
| Control voltage                          | 24 V DC                     |            |
| Electric motor power                     | 0.18 kW                     |            |
| Electric motor consumption               | 1 A                         |            |

| STANDARD MATERIALS              |   |
|---------------------------------|---|
| Filter housing and covers       | AISI-316 stainless steel                                  |
| Finish treatment                | Glass bead blasting                                       |
| Suction scanner                 | AISI-304 stainless steel                                  |
| Filtration mesh                 | AISI-316 stainless steel                                  |
| Suction nozzle                  | PVC with AISI 316 stainless steel ring and nylon bristles |
| Backwash valves                 | Polypropylene   |
| Bolting                         | A-4 stainless steel                                       |
| Joints                          | NBR – EPDM - Viton  |
| ULTRAVIOLET DISINFECTION        |   |
| Ultraviolet lamp                | Low voltage amalgam                                       |
| Number of lamps                 | 4 units   |
| UVC                             | 50 W  |
| Dose                            | 400 J / m <sup>2</sup>                                    |
| Transmittance                   | 45 %  |
| Lamp cleaning motor / Intensity | 24 V DC / 3A  |

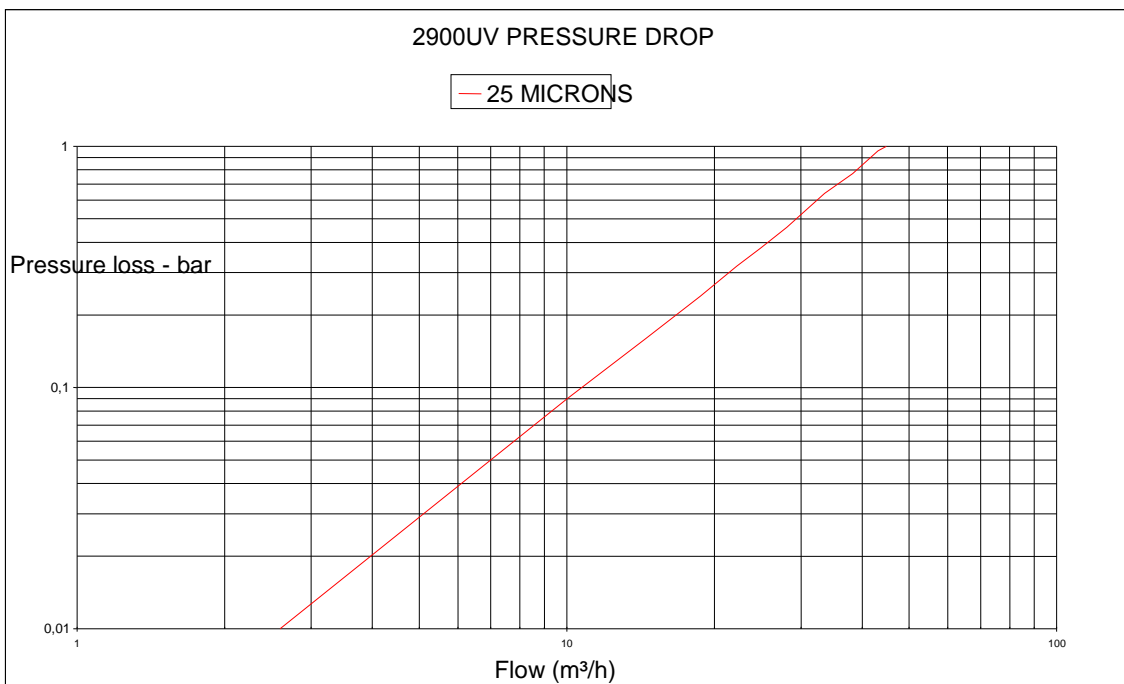
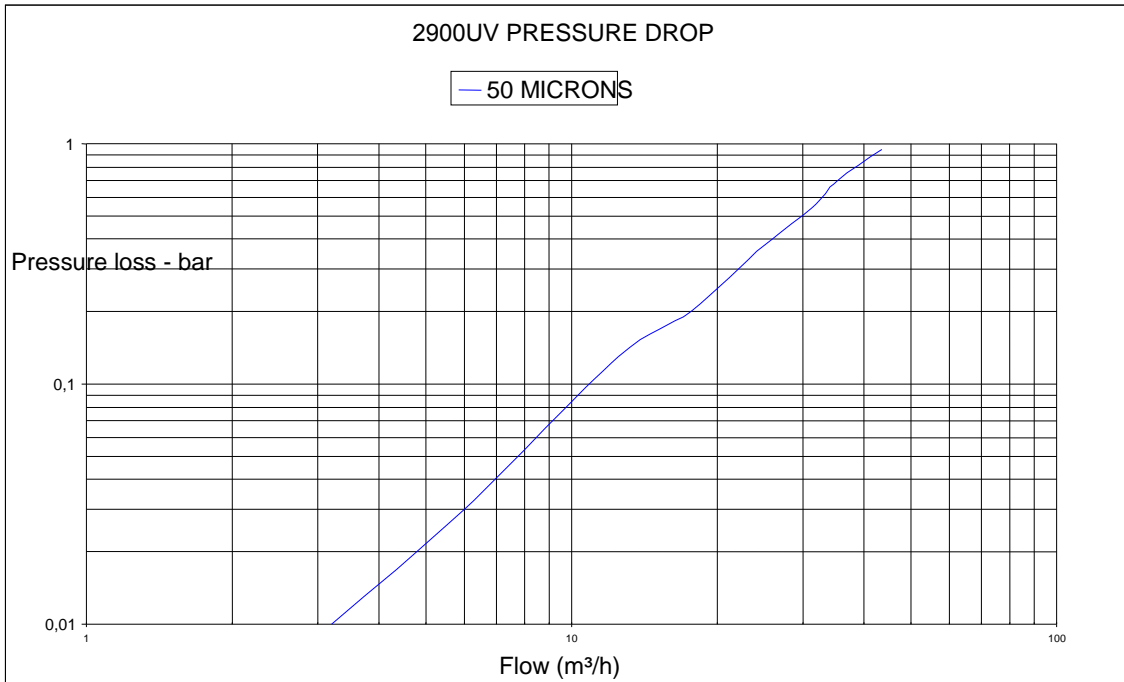

## 7. – NAMEPLATE

All devices are identifiable through an identification label attached to the filter.

|   |                        |  |  |  |  |
|---|------------------------|--|--|--|--|
|  |                        | Sistemas de filtración y<br>tratamiento de fluidos, S.A.<br>Pol. La Armentera, Parc. 87<br>Monzón (Huesca) |  |  |  |
| <b>FILTRO de DESINFECCION</b>   |                        |  |  |  |  |
| EQUIPO  | FMA Serie-7003         |  |  |  |  |
| DIÁMETRO ENT/SAL  | Brida DN-80 ( 8 aguj ) |  |  |  |  |
| Nº SERIE  | 0002 / 2010            |  |  |  |  |
| SUPERFICIE FILTRANTE  | 2900 cm <sup>2</sup>   |  |  |  |  |
| MALLA   | 20 mieras              |  |  |  |  |
| CAUDAL DE DISEÑO  | 26 m <sup>3</sup> /h   |  |  |  |  |
| PRESIÓN MÁXIMA DE TRABAJO   | 10 bar                 |  |  |  |  |
| PRESIÓN DE PRUEBA   | 15 bar                 |  |  |  |  |
| VÁLVULA DE DRENAJE  | 2" ROSCA               |  |  |  |  |
| POTENCIA INSTALADA  | 700 w                  |  |  |  |  |
| PESO EN VACIO ( Kg )  | 135 Kg                 |  |  |  |  |
| PESO EN CARGA ( Kg )  | 200 kg                 |  |  |  |  |
| DOSES   | 400 J/m <sup>2</sup>   |  |  |  |  |
| TRANSMITANCIA   | 45%                    |  |  |  |  |

The following information is provided on the label:

- Device.
- Inlet / outlet diameter.
- Device serial number.
- Filtration surface.
- Degree of filtration.
- Flow per design.
- Operational pressure.
- Backwashing valve.
- Power supply.
- Unit weight.
- CE Certificate.

## 8. – INSTALLATION GUIDE

- While in operation, the device generates intense ultraviolet radiation.

| <b>WARNING!</b>   |  |
|---|--|
|  | <p>HIGH INTENSITY ULTRAVIOLET RADIATION MAY CAUSE BLINDNESS</p> <p>SHIELD YOUR EYES AND FACE</p> |

- Take all necessary precaution to avoid the filter being struck; lift the unit using the anchor points on the upper section.
- Ensure the installation site has the minimum working pressure.
  - The discharge pipe must be large enough to generate a minimum pressure drop with a flow of 110 gpm.
  - A ball valve should be installed in the discharge pipe to adjust the backwash flow in installations with a working pressure above 6 bar (87 psi).

| <b>NOTE</b>   |  |
|---|--|
|  | <p>THE MINIMUM WORKING PRESSURE IS 2 BAR (29 PSI) BETWEEN THE FILTER OUTLET AND THE DRAIN VALVE.</p> <p>SHOULD DRAINAGE BE REDIRECTED, THIS MAY RESULT IN BACKPRESSURE DUE TO LOAD LOSS AND HEIGHT INCREASE.</p> |

- Install the filter horizontally; ensure there is sufficient space to easily access the unit for future treatments and to safely perform maintenance. See section 6.
- Orient the filter in the duct as indicated by the arrows showing the direction of water flow.
- The installation of a shut-off valve in the filter inlet and outlet is recommended to insulate it from the duct. A by-pass should be installed in order to avoid power cuts during maintenance.
- A non-return valve should be installed in the outlet to avoid any possible water hammer effect on the filter.
- The electrical wiring can only be installed by an approved electrician, per section 12.1.

- When installing the filter, take care not to let water splash on any electrical components or on the control panel.

## 9. – START-UP INSTRUCTIONS

- Check the points from the previous section.
- Check the hydraulic circuit (see section 15) which sends water to the backwash valve, ensuring that:
  - The ¾" filter is clean.
  - The ball valve is open.
  - The three-way valve is set to AUTO.
- Start with the following configuration at the shut-off valves:
  - Inlet valve: OPEN.
  - Outlet valve: CLOSED.
  - By-pass (where present): CLOSED.
- Connect the filter to the power supply, set the thermal breaker and the differential to ON.
- Ensure the programmable relay is set to RUN.
- Perform a manual backwash by pressing the manual backwash button. Section 12.2 details the backwash cycle.
- Open the outlet valve.  
While filling the network, pressure falls and flow increases, so it is advisable to install a pressure-sustaining valve in the outlet to ensure the network is filled in a controlled fashion.

### NOTE



SHOULD NO PRESSURE-SUSTAINING VALVE BE INSTALLED, WHILE FILLING THE NETWORK CLOSE THE OUTLET VALVE TO ATTAIN 2 BAR (29 PSI) ON THE CLEAN WATER CHAMBER MANOMETER. ONCE THE NETWORK IS PRESSURIZED, OPEN THE OUTLET VALVE TO WORK PROPERLY.

- Ensure the flow and installation pressure correspond to the maximums given for the specific model in this manual. See section 6.
- Check correct operation and load loss generated by the device once the start-up has finished.

**NOTE**

THE FILTER MAY AUTOMATICALLY START THE BACKWASH CYCLE WHEN THERE IS A PRESSURE DIFFERENCE OF 0.3 BAR (4.3 PSI) BETWEEN THE INLET AND THE OUTLET.

## 10. – MAINTENANCE GUIDE

- Disconnect the filter from the power supply before performing any maintenance.
- Ensure the filter has been depressurized prior to loosening the screws.
- Avoid splashes and water loss: This minimizes the risk of personnel slipping or electrocuting themselves, and any damage moisture may cause the device.
- After maintenance, reset the protective covers of the transmission mechanism.
- Manual cleaning of the filtration cartridge is performed using high-pressure water; where necessary acid or other chemical products may be used. This should be undertaken per the applicable instructions for the material in question and without endangering the operator or those nearby.
- Drain the unit during periods of prolonged inactivity.

### NOTE



ALWAYS OPEN AND CLOSE THE VALVES SLOWLY AND WITH CARE.

- While in operation, the device generates intense ultraviolet radiation.

### WARNING!



HIGH INTENSITY ULTRAVIOLET RADIATION MAY CAUSE BLINDNESS

SHIELD YOUR EYES AND FACE



## 11. – PREVENTIVE MAINTENANCE SCHEDULE

| MAINTENANCE                | PERIOD               | ELEMENT              | ACTION   |
|----------------------------|----------------------|----------------------|--|
| EXTERNAL                   |                      |                      |  |
| check filtration stage     | 1000 backwash cycles | Full filter          | Filter On + Filter manual backwash button<br>Check:<br><ul style="list-style-type: none"> <li>• motor start-up</li> <li>• valve opening</li> <li>• Effective backwash cycle (attain <math>P_1 = P_2</math>)</li> </ul> |
| check disinfection stage   | 1000 backwash cycles | Full filter          | Filter On + Reactor manual backwash button<br>Check:<br><ul style="list-style-type: none"> <li>• motor start-up</li> <li>• Effective cleaning cycle (restore radiation intensity)</li> </ul>                           |
| Check pressure transducers | 12 months            | Pressure transducers | Check the reading on the pressure transducers using the manometers on the unit.  |
| Check radiation sensor     | 12 months            | UV sensor            | Check the UV radiation intensity lies within proper working parameters.  |
| Check temperature sensor   | 12 months            | Sensor Temp.         | Check the temperature of the liquid is the same as the probe reading.  |
| anti-corrosion treatment   | 12 months            | FMA housing          | Use anti-corrosion treatment where necessary.<br>Apply Epoxy - Polyester treatment   |
| turret                     | 6 months             | Spindle              | Dismantle spindle cover and side grille.<br>Clean and lubricate both sides of the spindle.<br>Use lubricant from STF-Filtros.  |
| Rim water-tightness        | 6 months             | Rim water-tightness  | Check water-tightness of element.<br>Replace internal joints:<br><ul style="list-style-type: none"> <li>• O-ring Ø45x4 Joint NI – 150 20x28x5,5</li> <li>• Quad joint EQ-16</li> <li>• Scraper 20X28X4.8/7</li> </ul>  |
| Pressure line              | 1 week               | Intake filter        | Cleaning of intake filter and water supply micro-tubes towards backwash valve  |

| MAINTENANCE              | PERIOD                | ELEMENT                              | ACTION  |
|--------------------------|-----------------------|--------------------------------------|---|
| INTERNAL                 |                       |                                      |   |
| anti-corrosion treatment | 12 months             | FMA housing                          | Use anti-corrosion treatment where necessary.<br>Apply Epoxy - Polyester treatment.           |
| Suction nozzles          | 12 months             | Suction nozzle                       | Check state of suction nozzles, bristles, proximity to cartridge.                             |
| Bushes                   | 12 months             | Lamp cleaning bushes                 | Check state of cleaning bushes: should have no looseness or flaws.                            |
| Brushes                  | 12 months             | Disinfection chamber cleaning brush. | Check state of bristles, proximity to chamber walls.  |
| Roughing cartridge       | 12 months             | Roughing cartridge                   | Cleaning of roughing cartridge.   |
| Filtration cartridge     | Periods of inactivity | Filtration cartridge                 | Manual cleaning using high-pressure water, where necessary use acid or other chemical agents. |
| Lamps                    | 12 months             | Lamps UV                             | Using a clean cloth, manually clean the surface of the lamp.                                  |
| Joints                   | 12 months             | Internal joints                      | Check internal joints; where deteriorated, replace immediately.                               |

## 12. – CONTROL PANEL

When an Omicron 2900UV is supplied, all the electrical connections between the control panel, the sensors and the actuators come pre-installed and tested by the manufacturer.

The default power setting for the unit is 400V AC, 50Hz; for variations, consult the manufacturer.

### WARNING!



FOR PANELS POWERED BY THREE-PHASE CURRENT, DURING THE START-UP THE MOTOR DIRECTION SHOULD BE CHECKED SO IT IS IN LINE WITH THE FILTER PROGRAM.

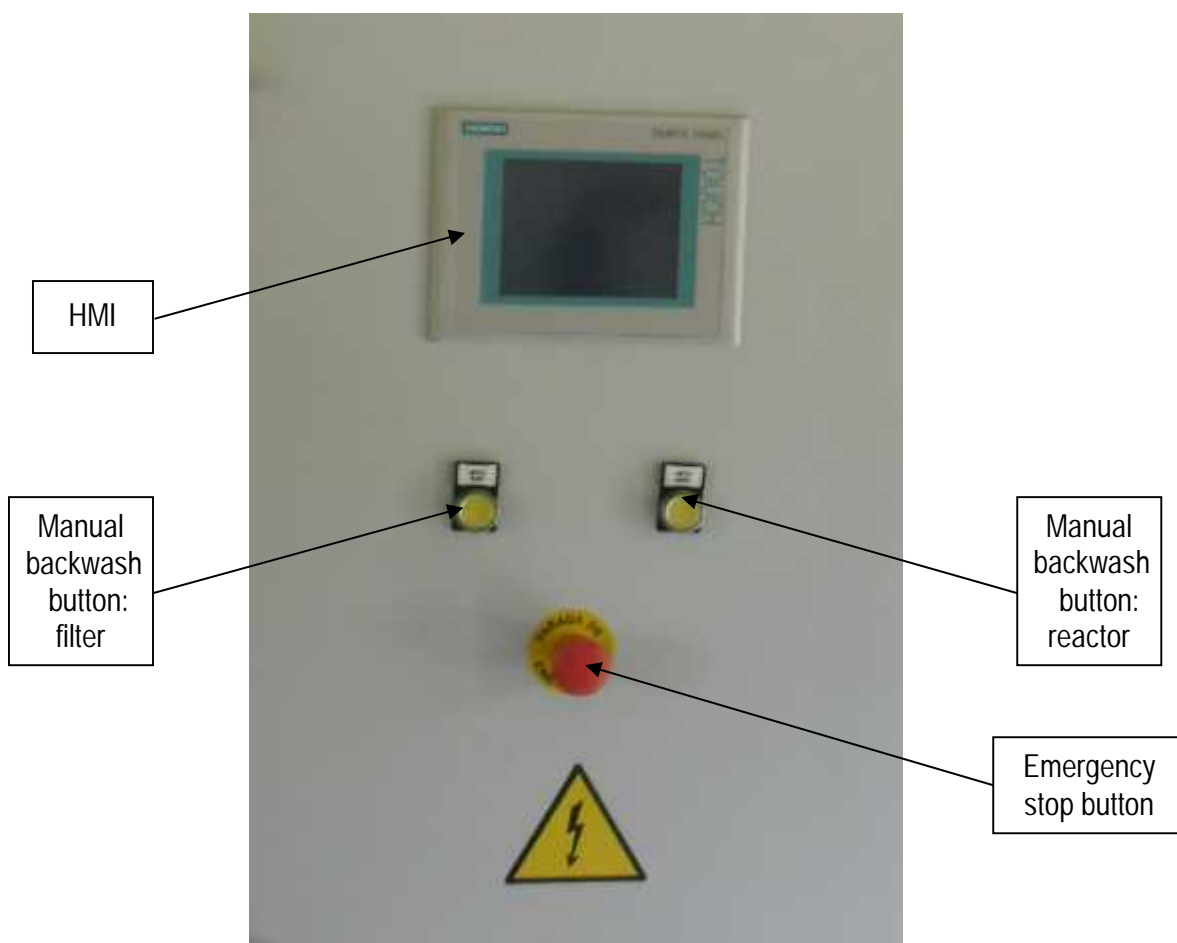



## 12.1. – CONNECTION

**WARNING!**

RISK OF ELECTRIC SHOCK. OPERATIONS WITH THIS SYMBOL MUST ONLY BE PERFORMED BY QUALIFIED SPECIALIST TECHNICIANS.

The unit's power, sensors and actuators are connected in the lower terminals, per the following specification:

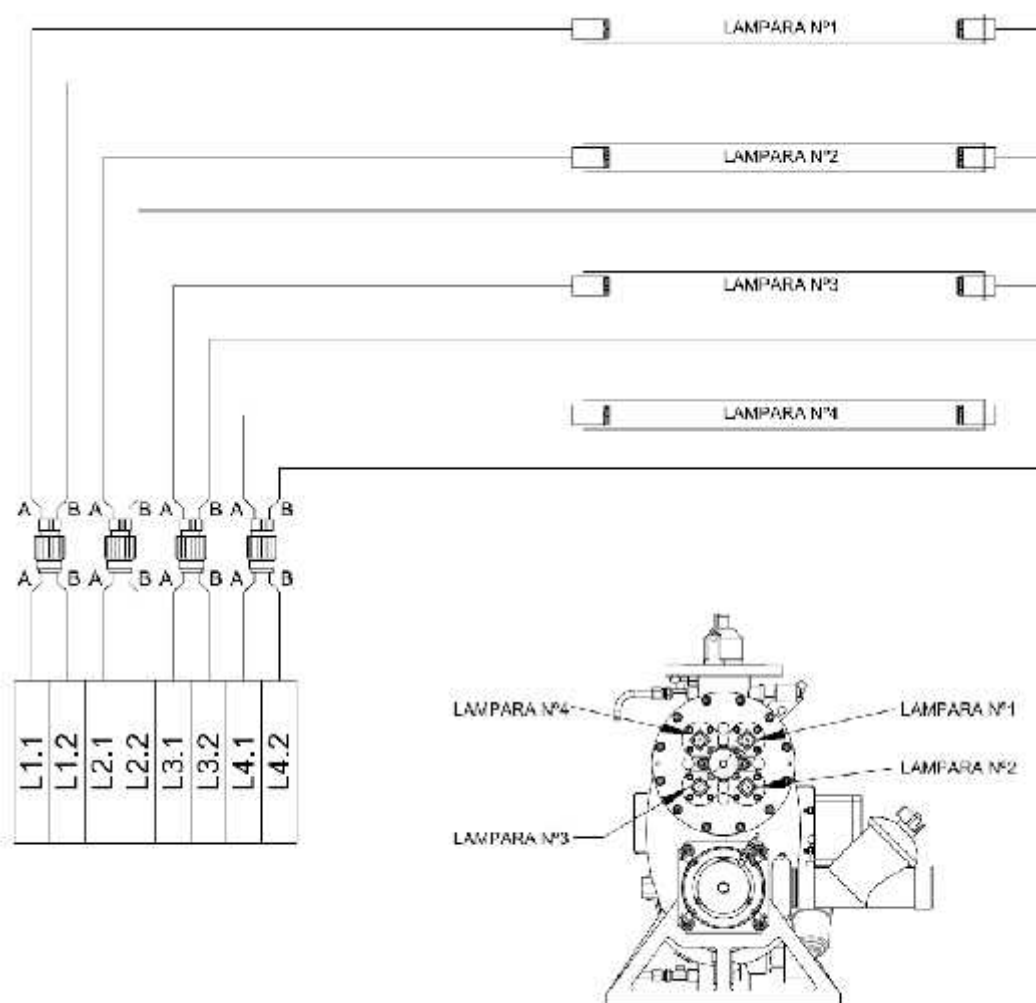

Lamp No. 1; Lamp No. 2; Lamp No. 3; Lamp No. 4

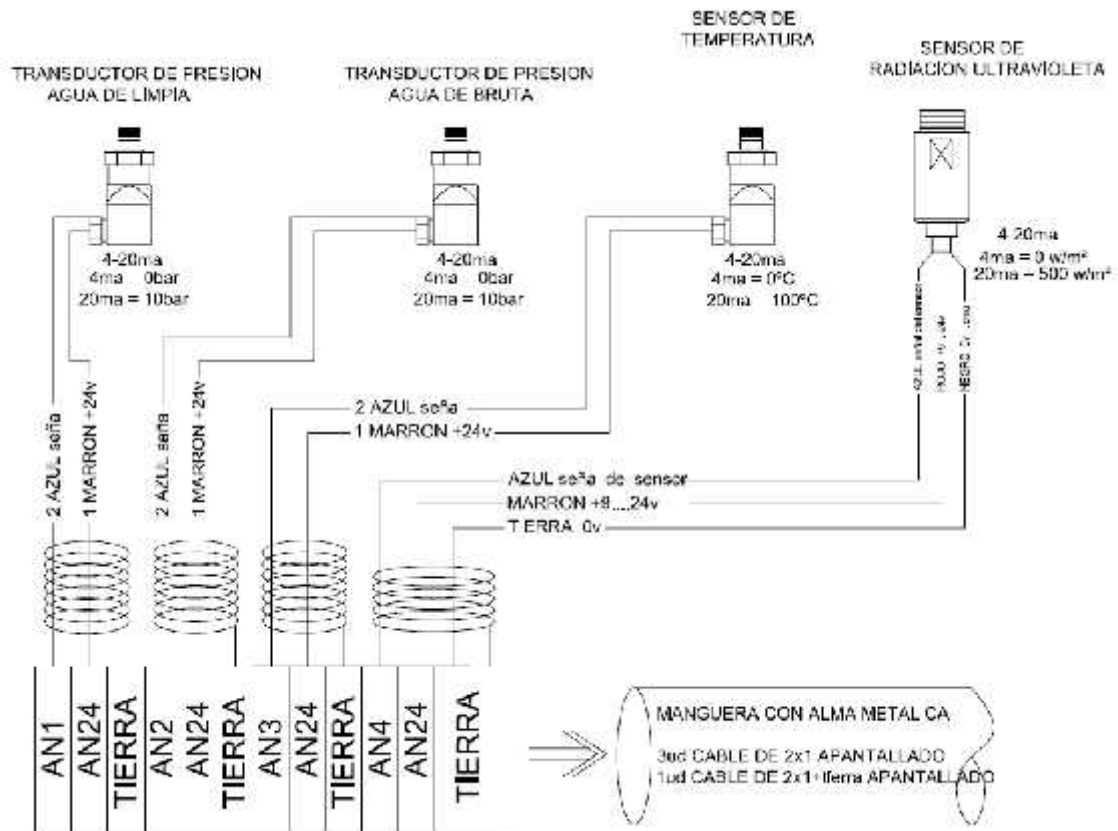

CLEAN WATER PRESSURE TRANSDUCER; 2 BLUE signal; 1 BROWN + 24v; RAW WATER PRESSURE TRANSDUCER; 2 BLUE signal; 1 BROWN + 24v; TEMPERATURE SENSOR; 2 BLUE signal; 1 BROWN + 24v; ULTRAVIOLET RADIATION SENSOR; BLUE sensor signal; BROWN +9...24v; EARTH; BLUE sensor signal; RED +9...24v; BLACK 0v earth

AN1; AN24; EARTH; AN2; AN24; EARTH; AN3; AN24; EARTH; AN4; AN24; EARTH; HOSE WITH METAL T-TRACK; 3 units 2 X 1 SHIELDED CABLE; 1 unit 2 X 1 SHIELDED earth (A = blue; N = black)

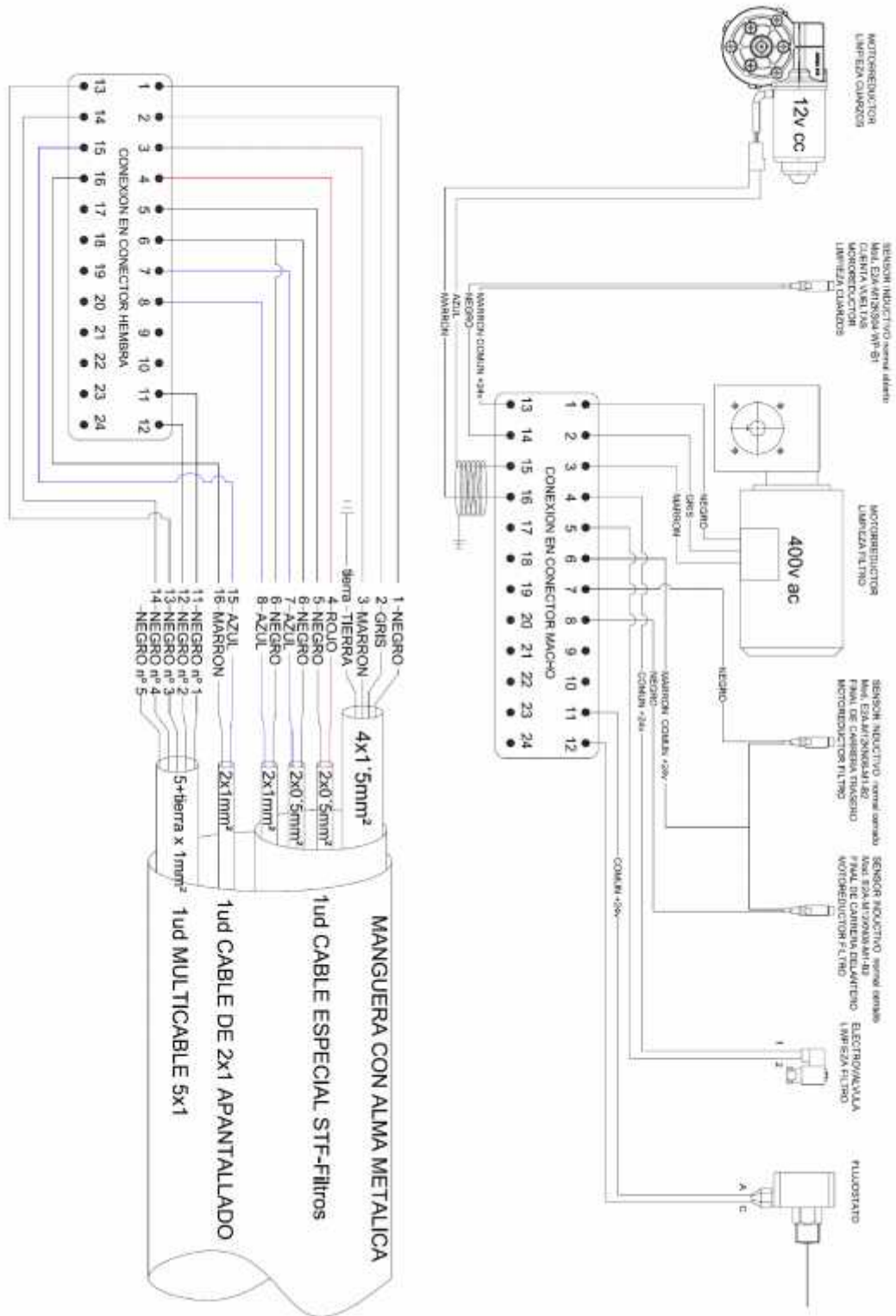

## 12.2. – OPERATION

### HOME SCREEN

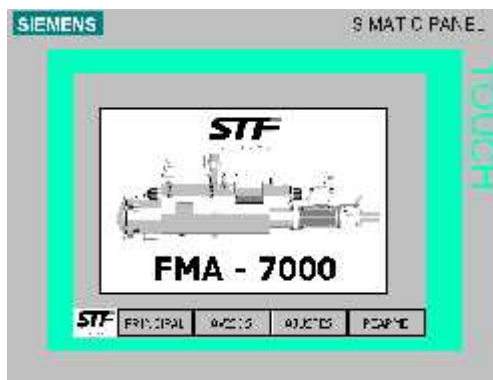

Touching the screen takes us to the HOME SCREEN. The screen has the following touch buttons:

- STF ⇒ HOME SCREEN
- MAIN ⇒ MAIN SCREEN
- NOTIFICATIONS ⇒ NOTIFICATION SCREEN
- SETTINGS ⇒ SETTINGS SCREEN
- RESET ⇒ RESET TOUCH BUTTON

These five buttons are present on all the screens with the same purpose throughout.

### MAIN SCREEN

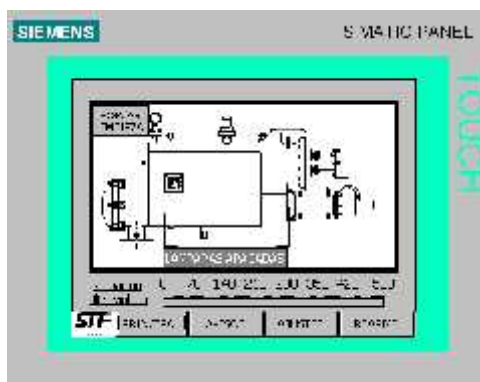

The screen monitors the following information using blocks of text:

- "Filter pressure differential exceeded"
- "Insufficient flow in reactor"
- "Recirculation activated"
- "Lamps off"
- Backwash filtration cleaning time in seconds.
- Disinfection stage cleaning time in seconds.
- Continuous reading of ultraviolet radiation.



This screen has the PERFORM CLEANING touch button, which leads to a pop-up with the following touch buttons:

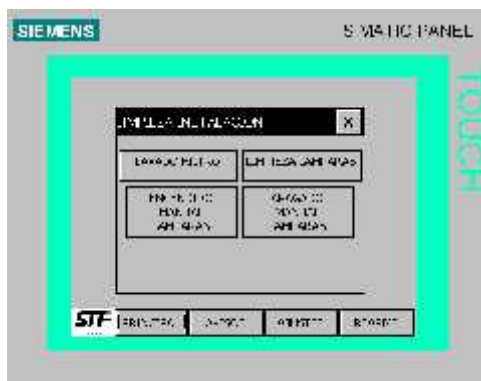

- BACKWASH FILTER (manual)
- CLEAN LAMPS (manual)
- MANUAL LAMP ON-SWITCH
- MANUAL LAMP OFF-SWITCH

## SETTINGS SCREEN



This is a menu with the unit settings; each touch button takes you to the corresponding pop-up:

- FILTER PARAMETERS



The following parameters can be set:

- "Maximum number of consecutive backwashes" in the mesh (typical: 10)
- "Pressure tare differential" in bar. (standard: 0.3 bar / 4.3 psi)
- "Backwash length timer" in hours and minutes (standard: 12:00)

The screen monitors the following information:

- Time since the last backwash cycle in the mesh - in hours, minutes and seconds.
- UV-C REACTOR PARAMETERS



The following parameters can be set:

- "Maximum number of consecutive backwashes" in the reactor (typical: 10)
- "Backwash length timer" in hours and minutes (standard: 01:00:00)
- "Minimum UV-C tare dose" in W/m<sup>2</sup>. (standard: 36 W/m<sup>2</sup>)
- "Maximum water temp tare" in °C (standard: 40°C).

The screen monitors the following information:

- Time since the last cleaning cycle for the lamps - in hours, minutes and seconds.
- SCREEN SETTINGS



The screen has the following touch buttons:

- BACKWASH SCREEN ⇒ Allows the screen to be blocked for cleaning
- TOUCH CALIBRATION ⇒ Allows screen to be set.
- CLOCK ⇒ Allows the date and time of the PCU.
- TRANSFER ⇒ The screen is in programme loading mode.

- RECIRCULATION SYSTEM



Safety system so the temperature of the liquid in the system does not exceed the setpoint at which lamps should be switched off.

The following parameters can be set:

- "Temperature tare before recirculation system connected" in °C
- "Recirculation time" in seconds

The screen monitors the following information:

- State of the UV lamps (on/off)
- Number of recirculations (resettable parameter)

- PRESSURE

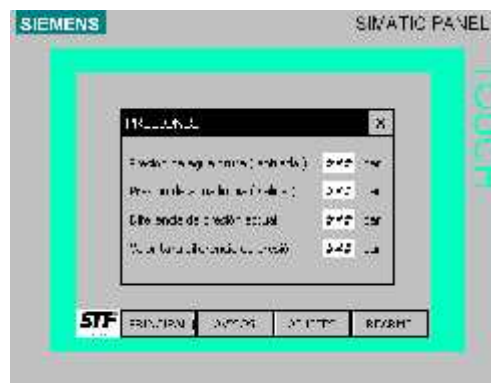

The screen monitors the following information:

- "Raw water pressure" in bar.
- "Clean water pressure" in bar.
- "Current pressure differential" in bar.
- "Pressure differential tare" before the mesh backwash cycle begins, in bar.

- PRESSURE



The screen monitors the following information:

- "Water temperature" in °C
- "Maximum water temp. tare" in °C
- "Current UV-C radiation" in W / m<sup>2</sup>
- "Minimum UV-C tare dose" in W/m<sup>2</sup>
- "UV-C radiation differential" in W / m<sup>2</sup>

- OPERATION RECORDS

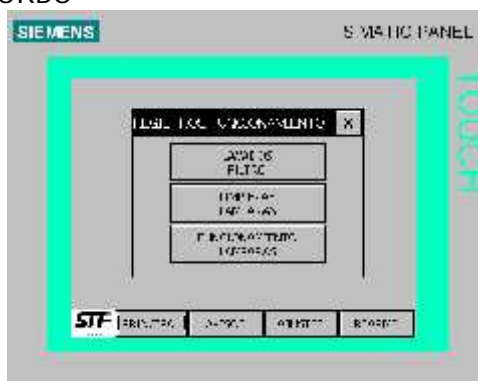

The menu provides access to the records for: filter backwash and lamp cleaning plus the operational time for both.

The screen has the following touch buttons:

- FILTER BACKWASH ⇒

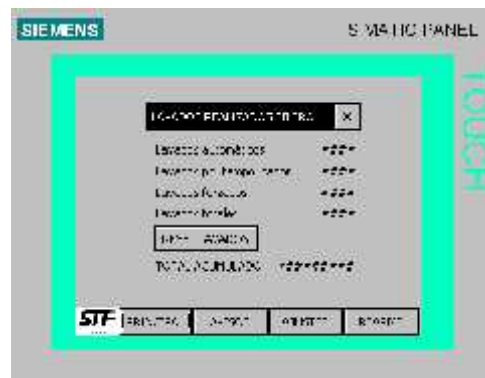

- CLEAN LAMPS ⇒

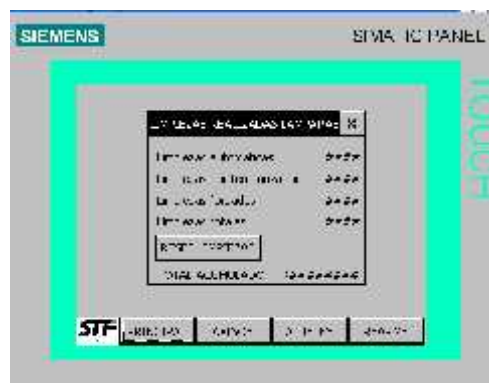

- LAMP OPERATIONS ⇒



## SETTINGS SCREEN

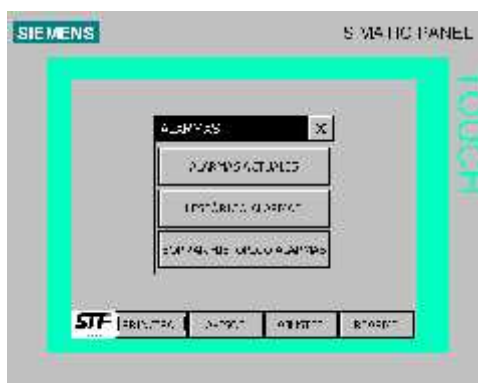

The menu provides access to the record of alarms from the unit; this screen has the following touch buttons:

- CURRENT ALARMS ⇒ Real-time alarm monitoring.
- ALARM HISTORY ⇒ Records alarms from the unit.
- ERASE ALARM HISTORY ⇒ Alarm history can be reset.

### 13. – WARNINGS AND ALARMS

| TEXT                               | DESCRIPTION   |
|------------------------------------|---|
| EMERGENCY STOP BUTTON              | Press filter emergency switch to activate.  |
| MOTOR PROTECTION SWITCH ACTIVATED  | Caused by either the filter motor protection switch or the lamp motor switch going off.   |
| FAULT LAMP LIMIT                   | Occurs if the bushes fail to cover the whole of the surface of the lamps during the reactor backwash cycle.   |
| FAULT FILTER LIMIT                 | Occurs if the suction nozzles fail to cover the whole of the surface of the filtration cartridge during the backwash cycle.   |
| CONSECUTIVE CLEANING: LAMPS        | Occurs when the no. of consecutive reactor cleaning cycles has no effect on increasing the measured uv intensity. (The no. of cleaning cycles is a settable parameter)                  |
| CONSECUTIVE FILTER CLEANING CYCLES | Occurs when the no. of consecutive mesh cleaning cycles has no effect on reducing pressure differential to normal clean screen PD. (The no. of cleaning cycles is a settable parameter) |
| ELECTRICAL PANEL TEMP. EXCEEDED    | Occurs when the inside of the electrical panel is above 40 °C.  |
| REACTOR WATER TEMP. EXCEEDED       | Occurs when the liquid inside the unit is above 40 °C.  |
| UV-C DOSE BELOW MINIMUM            | Occurs when the radiation intensity is below the minimum threshold. (The minimum value is settable)   |
| LAMP CABLE DISCONNECTED            | Occurs when the connector powering the lamp instruments comes free.   |
| FILTER CABLE DISCONNECTED          | Occurs when the connector powering the filter instruments comes free.   |

## 14. – HYDRAULIC CIRCUIT

The filter has a hydraulic valve to expel the backwash flow. This valve remains closed when water enters the upper chamber and opens to drain the chamber when the solenoid is activated.

The valve can be mechanically regulated; thus the backwash flow can be adjusted for installations with pressure above 6 bar (87 psi).

The opening and closing process is automatic and uses a 24V DC NO (normally open) solenoid. As specified in the attached schematic.

The three-way valve remains set to AUTO; it can be operated manually using OPEN and CLOSE.

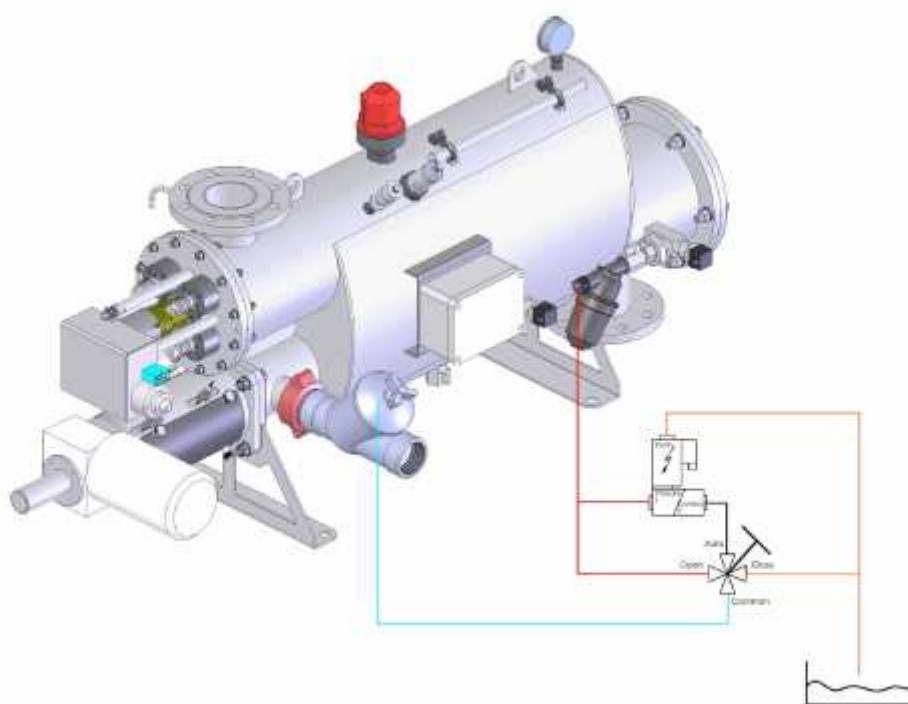

Solenoide NO  
24v. Dc

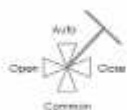

Valvula 3 Vias

----- Linea de Presion en Alta

----- Linea de Venteo

----- Linea de Comando

**WARNING!**

REGULAR CLEANING WILL MAINTAIN THE FILTER PROTECTING THE CIRCUIT.

OPERATIONAL PROBLEMS MAY BE CAUSED BY CONVEYANCE OF DRAINAGE OVER LARGE DISTANCES.

**NOTE**

THE PRECEDING SCHEMATIC IS VALID FOR STANDARD DEVICES AT MAX. 10 BAR PRESSURE.

CONSULT THE MANUFACTURER FOR OTHER PRESSURES.



Sistemas de Filtrado y Tratamientos de Fluidos S.A.  
Pol. Armentera Parc. 87  
22400 Monzón (Huesca / Spain)  
Tel.: +34 974 401 933  
Fax: +34 974 417 809  
[info@stf.filtros.com](mailto:info@stf.filtros.com) / [www.sft-filtros.com](http://www.sft-filtros.com)